

The SW300 is designed for use in telecommunication and power distribution applications where an uninterrupted load is switched. These contactors are primarily for use with Direct Current loads but can also be used with Alternating Currents.

- **Uninterrupted current** - no or infrequent load switching requirements (maintains a lower contact resistance).

Application	Uninterrupted
Thermal Current Rating (¹ th)	300A
Intermittent Current Rating:	
30% Duty	550A
40% Duty	475A
50% Duty	425A
60% Duty	390A
70% Duty	360A

The SW300 features double breaking main contacts with silver alloy tips which are weld resistant, hard wearing and have excellent conductivity. Silver plating on the main contacts is standard for the SW300, however optionally it can be excluded from the specification. The SW300 is a compact contactor which can be busbar mounted vertically or horizontally, if mounted vertically the coil should be at the bottom.

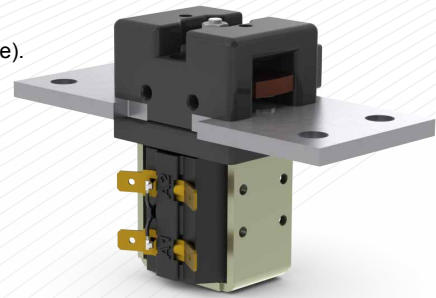

SW300A (Auxiliary at Rear)

Rated Fault Current Breaking Capacity (¹ cn) Resistive Load: (in accordance with UL508*)	450A at 60V D.C.
Maximum Recommended Contact Voltages (U _e):	
SW300	60V D.C.
Typical Voltage Drop per pole across New Contacts at 100A	50mV
Mechanical M.T.B.F	>1 x 10 ⁶
Coil Voltage Available (U _c) (Rectifier board required for A.C.)	From 6 to 240V A.C./D.C.
Coil Power Dissipation:	
Highly Intermittent Rated Types	20 - 30 Watts
Intermittently Rated Types	15 - 20 Watts
Prolonged Rated Types	13 - 15 Watts
Continuously Rated Types	7 - 13 Watts
Maximum Pull-In Voltage (Coil at 20° C) Guideline:	
Highly Intermittent Rated types (Max 25% Duty Cycle)	60% U _s
Intermittently Rated types (Max 70% Duty Cycle)	60% U _s
Prolonged Operation (Max 90% Duty Cycle)	60% U _s
Continuously Rated Types (100% Duty Cycle)	66% U _s
Drop-Out Voltage Range	10 - 30% U _s
Typical Pull-In Time	15ms
Typical Drop-Out Time (N/O Contacts to Open):	
Without Suppression	6ms
With Diode Suppression	35ms
With Diode and Resistor (Subject to resistance value)	20ms
Typical Contact Bounce Period	< 5ms
Operating Ambient Temperature	- 40°C to + 60°C
Guideline Contactor Weight:	
SW300	560 gms
With Auxiliary	+ 20 gms

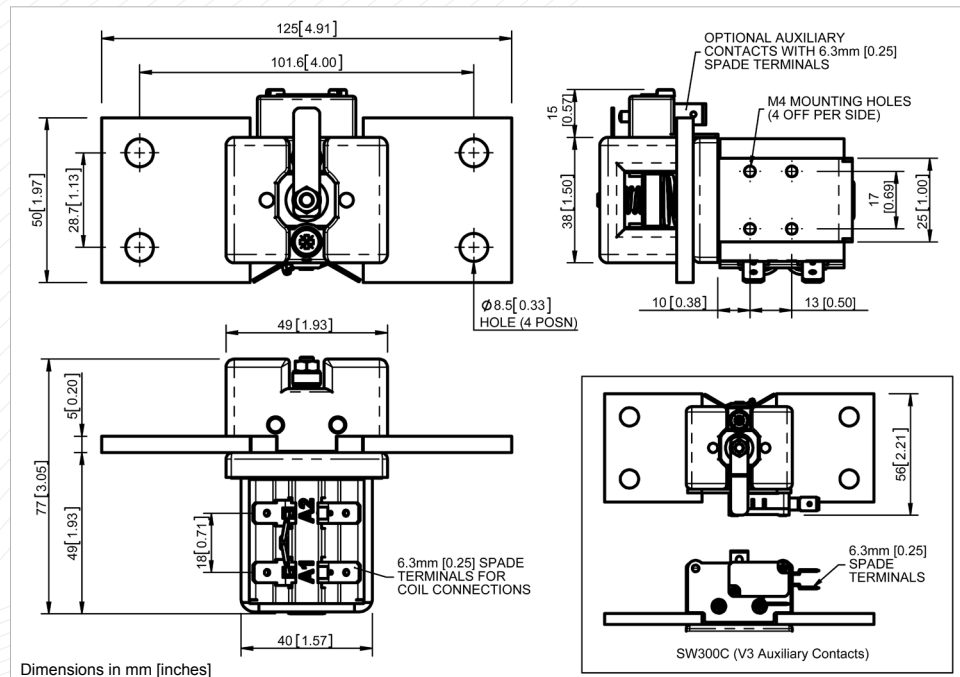

Auxiliary Details	
Auxiliary Thermal Current Rating	5A
Auxiliary Contact Switching Capabilities (Resistive Load):	
SW300A	SW300C
	5A at 24V D.C.
	2A at 48V D.C.
	1.3A at 72V D.C.

Advised Connection Sizes for Maximum Continuous Current	
Copper busbar	194mm ² [0.30inch ²]
Cable	Rated Suitable for Application

Key: ▲ Uninterrupted
 Note: Where applicable values shown are at 20° C
 * Please check our web site for product UL status

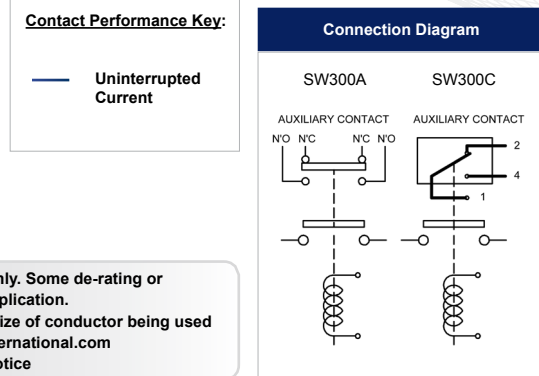
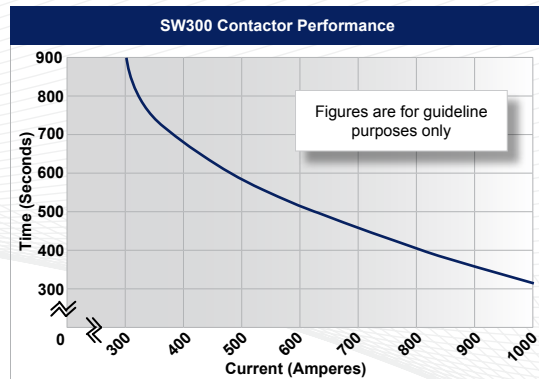

SW300 Available Options		
General		Suffix
Auxiliary Contacts	○	A
Auxiliary Contacts - V3	○	C
Magnetic Blowouts†	X	
Magnetic Blowouts - High Powered†	X	
Armature Cap	X	
Mounting Brackets (see Busbar Series Catalogue)	○	
Magnetic Latching† (Not fail safe)	○	M
Closed Contact Housing	X	
Environmentally Protected IP66	X	
EE Type (Steel Shroud)	X	
Contacts		
Large Tips	X	
Textured Tips	X	
Silver Plating (fitted as standard)	○	
Coil		
AC Rectifier Board (Fitted)	○	
Coil Suppression†	○	
Flying Leads	○	F
Manual Override Operation	○	
M4 Stud Terminals	X	
M5 Terminal Board	○	
Vacuum Impregnation	○	
Key: Optional ○ Standard ● Not Available X		
† Connections become polarity sensitive		

- Performance data provided should be used as a guide only. Some de-rating or variation from figures may be necessary according to application.
- Thermal current ratings stated are dependant upon the size of conductor being used
- For further technical advice email: technical@albrightinternational.com
- Albright reserve the right to change data without prior notice